



418/433 MHz short-range communication licence-exempt data transmission and remote control systems

In the UK, two small sections of the 70-cm band, around 418 MHz and 433 MHz, have been available for some time for licence-exempt wireless communication using type-approved low-power devices (LPDs), also called short-range devices (SRDs). In this article we look at the use of these frequency bands, and some general design considerations for SRD modules.

The history of licence-exempt use of radio transmitters started a few decades ago with the private use of low-power transmitters for radio-controlled models. Much later, CB radio in the 27-MHz band was legalised and type-approved radios for this band were freely available. However, the use of type-approved radio-control transmitters as well as that of CB rigs was tied to a licence fee and some administration. And then, the mere disappearance of the dreaded paperwork and, possibly, a test, to get your licence was hailed as a great liberalisation. The result of this de-regulation on part of the government authorities was a boom in the sales of CB radios. A few years later, the overcrowded CB band was extended with quite a few channels, higher transmit power was allowed, as well as FM (frequency modulation).

Although small sections of the 40 MHz and 173 MHz bands (the latter exclusively in the UK) have long been available for low-power devices like 'stage microphones' and remote controls (for example, for garage doors), nothing was allowed without paying a licence-fee and proof that the equipment was type-approved.

Many of the regulations, but not the type-approvals, have been relaxed or changed radically over the past few years. Initially, licence-exempt remote control systems appeared for the CB 27 MHz (11-m) band. The real activity did not start however until two small sections of the 70-cm band, 418 MHz and 433 MHz, were 'released' for low-power type-approved devices (LPDs), also called short-range devices (SRDs).

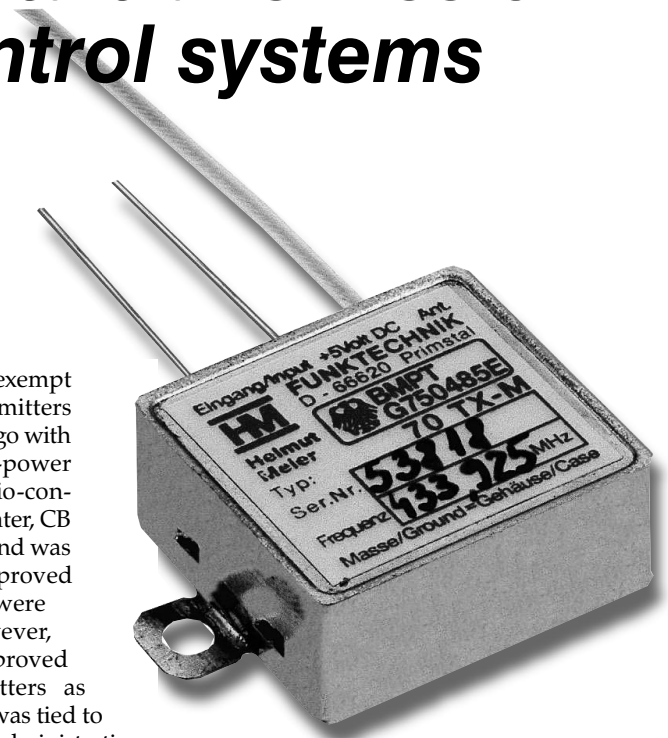

In Europe, the national radio regulation authorities (in the UK : Radiocommunications Agency, RA) have their own say about the use of the SRD bands. In the UK, the 418 MHz section may be used for telemetry transmitters and receivers, telecommand and in-building security equipment, while the 433-MHz section is only available for in-vehicle equipment including radio keys. This is in contrast with many other European countries, where the section around 433 MHz is much wider and also available for all of the aforementioned applications, and even voice communications using 10-mW FM handhelds.

In the UK, the specification with number MPT1340 is applicable to all LPDs using the 418 MHz and 433 MHz sections of the 70-cm band. The Radiocommunications Agency (RA) is an Executive Agency of the DTI (Department of Trade and Industry) responsible for the allocation, maintenance and supervision of the UK radio spectrum. The RA can be contacted at the following address: Radiocommunications Agency, New King's Beam House, 22 Upper Ground, London SE1 9SA. Tel. (0171) 211 0211, fax 211

0507. Internet: www.open.gov.uk/radiocom.

Document number I-ETS 300 220 describes the type-approval requirements for 418/433-MHz SRDs. According to the RA, new equipment can only be type approved to this standard provided parameter limits stated in MPT 1340 are met.

EX-ISM FREQUENCIES

A long time ago, the current SRD band section at 433 MHz was part of a slightly larger section reserved for ISM (industrial, scientific and medical) equipment producing RF radiation. Mainly as a result of pressure from licensed radio amateurs who use this part of the band on a shared and/or secondary basis, the use of ISM equipment has been phased out, and the band section is no longer identified as such, at least not in the UK. Several other ISM frequency bands are defined in the UK, including 167 MHz, 83 MHz and 40 MHz, all subject to strict regulations, the most essential of which being very low ERP (effective radiated power) levels.

The exact frequency allocation of the 418 MHz and 433 MHz SRD bands is shown in Figures 1a and 1b. It should be noted that the channel division and channel widths have been adopted by SRD manufacturers, there being no strict RA regulation in this respect.

It is expected from radio amateurs using the 70-cm band to accept the activity of low-power SRD users in this part of the band and not cause interference. Likewise, SRD users have to live with interference caused by radio amateurs, or prevent interference by using low transmission rates, sure codes, high redundancy and selective receivers. All of this is, of course, in the hands of the manufacturers of SRDs, because the users are not allowed to make changes to type-approved equipment.

A NEW SRD BAND

Meanwhile, because they are so small, the 418 MHz and 433 MHz SRD bands have become quite overcrowded. A new band, around 886 MHz, is 'identified' by the relevant authorities for use by SRDs (Figure 2), with reference to CEPT Recommendation T/R 70-03. In this band, it is planned to reserve several channels exclusively for security applications. Some channels in the proposed frequency range are, however, still in use for analogue cordless telephone sets of the CT2 generation.

For all SRD bands, the intention has always been to arrive at unified regulations. In the UK, however, the Radio-communications Agency "has not adopted CEPT recommendation TR 01-4 which allows general low-

1

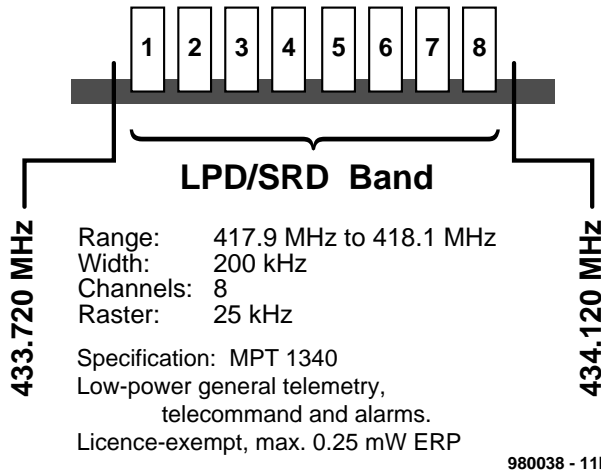
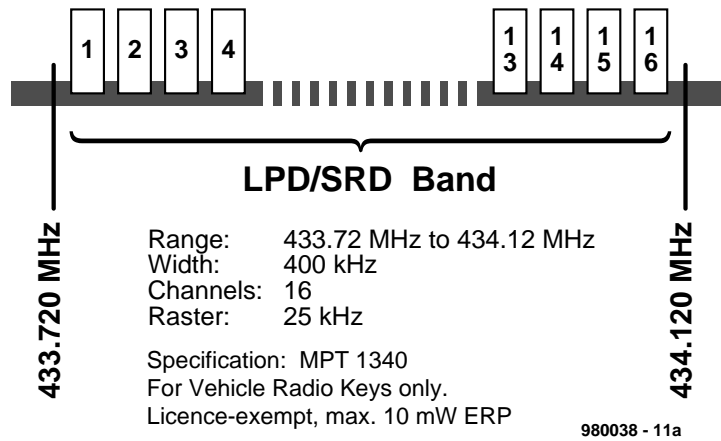
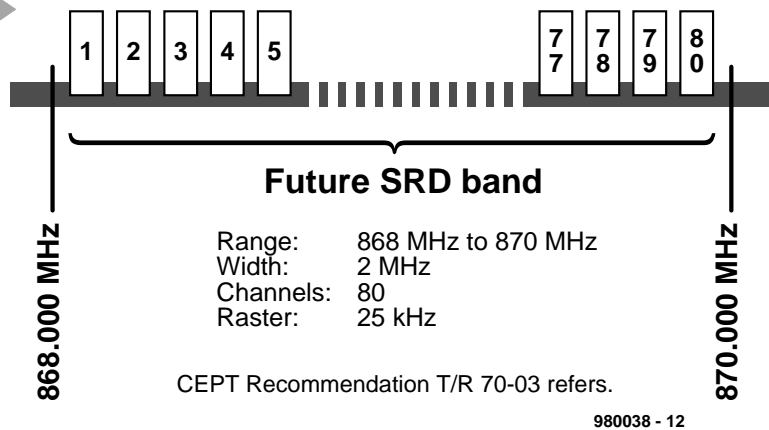

Figure 1. Frequency allocation and (manufacturer-proposed) channel division of the two 70-cm SRD bands available in the UK.

Figure 2. Plans are afoot to open the 886-MHz band for SRD use.

2



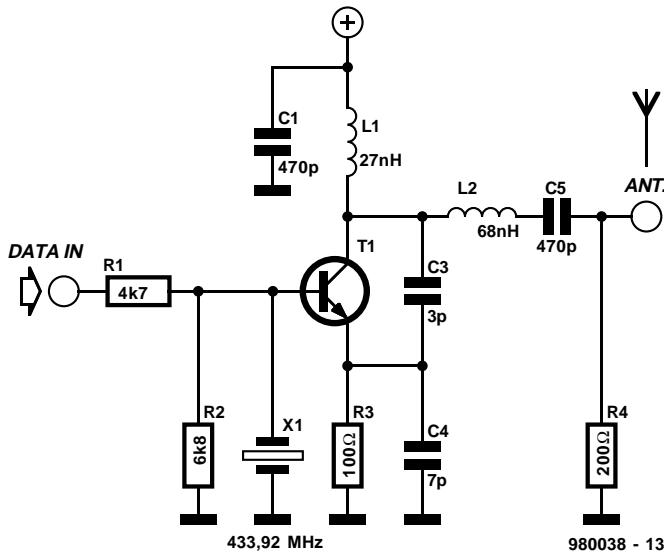

Figure 3. Circuit diagram of an ultra-simple 433-MHz SRD transmitter using amplitude modulation (not type-approved by RA).

Figure 4. Circuit of a simple AM receiver module using a single transistor in the (regenerative) RF section (not type-approved by RA). In some cases, there's an additional preamplifier stage using a second transistor.

power devices to operate in this band". Hopefully, the 886 MHz SRD band will be graced by cross-European standards, and receive an ETS (European Telecommunication Standard).

LPD MODULES

In this country, RadioMetrix and RadioTech are the main suppliers of ready-made, type-

approved receivers and transmitters for short-range communications in the 418/433 MHz bands. In this context, we should also mention the activities of the LPRA, the Low-Power Radio Association, who publish an interesting and highly topical newsletter, as well as maintain a fine Internet web site at www.lpra.org.uk

The ready-made, UK type-approved LPD modules from RadioMetrix and RadioTech come in a variety of frequencies and transmit powers, depending on your application and country of use. Modules are also available for digital communications between, say, a PC and a printer, the radio link effectively acting as a very long RS232 cable. All LPD mod-

ules we have seen so far contain SMD parts to keep the overall size as small as possible.

The simplest versions of SRDs used to rely on an amplitude-modulated transmitter (Figure 3) and an associated regenerative receiver (Figure 4). Note that such systems are probably no longer allowed under RA specification MPT 1340. The transmitter consists of a one-transistor oscillator. Modulation is obtained by applying the data signal to the base of the transistor. A single surface-acoustic wave (SAW) resonator is used as the frequency-determining element. A highly similar circuit for experimental use was published in *Elektor Electronics* July/August 1993, page 54. Note, however, that this design is based on frequency modulation (FM) using two varicap diodes, while the SAW has a fine-tuning adjustment.

The receiver shown in Figure 4 also contains just one transistor. It is biased to act as a regenerative oscillator, in which the received antenna signal causes the transistor to switch to high amplification, thereby automatically arranging the signal detection. Next, the 'raw' demodulated signal is amplified and shaped-up by opamps. The result is a fairly clean digital signal at the output of the receiver. The logic-high level is at about 2/3 of the supply voltage, i.e., between 3 V and 4.5 V.

The range of the simple system shown in Figures 3 and 4 is much smaller than that of more expensive units, mainly because of the low transmit power (approx. 1 mW) and the rel-

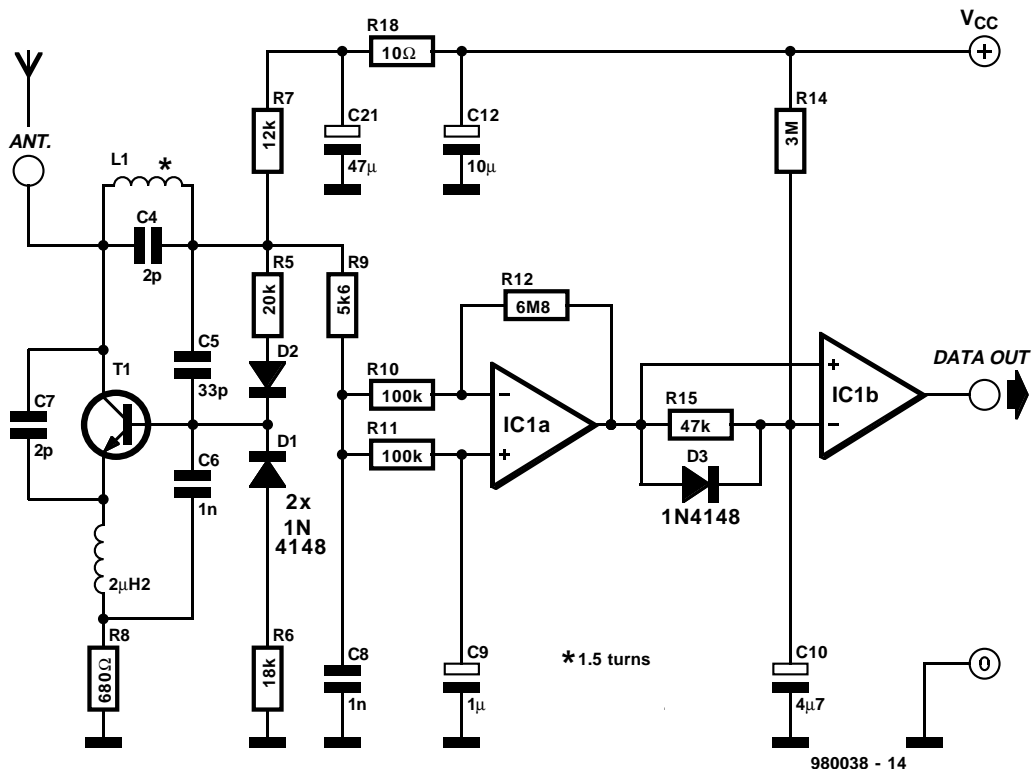

active insensitivity and wide-band nature of the receiver. Moreover, amplitude-modulated noise is not suppressed in any way.

For more demanding applications, FM (frequency modulation) is the obvious alternative. Block diagrams of an LPD-type 433-MHz FM transmitter and its associated receiver are shown in Figures 5 and 6 respectively.

The transmitter is automatically actuated by means of pulse edge detection, and uses an accurately defined 4-ms time slot to transmit, as soon as data pulses are detected at the input. When the data signal is removed, the transmitter automatically returns to standby mode after about 200 ms. As in the lower-spec transmitter, the frequency stability is derived from a SAW resonator. The main advantage of these resonators is their low cost. On the down side, they are subject to relatively large production tolerances, and their temperature stability is a far cry from that of a quartz crystal.

To keep the bandwidth of the frequency modulated transmitter output signal within limits, the frequency deviation is limited (± 2.5 kHz to ± 20 kHz, depending on the SAW type and manufacturer). The input data rate is also limited (low-pass filter). The upshot is that the highest data rate of the FM modules is about 10 kBit/s (using a highest modulation frequency of 5 kHz).

The antennas used for SRDs are traditionally produced in the form of a printed-circuit board track, while λ -lambda flexible antennas are also seen occasionally.

The FM receiver module shown in the block diagram (Figure 6) is a superheterodyne design. Here, too, an SAW resonator is used in the oscillator to ensure frequency stability. All of the intermediate-frequency (IF) filtering can be done with low-cost 10.7-MHz ceramic filters. Because of the possible frequency offset caused by the SAW resonator, a fairly large bandwidth (approx. 280 kHz) is required anyway. Most ready-made SRD receiver modules are compatible with 5-V or 3-V systems.

Thanks to miniaturisation, SRD

5

Figure 5. Block diagram of a typical FM transmitter module for one of the 70-cm SRD bands.

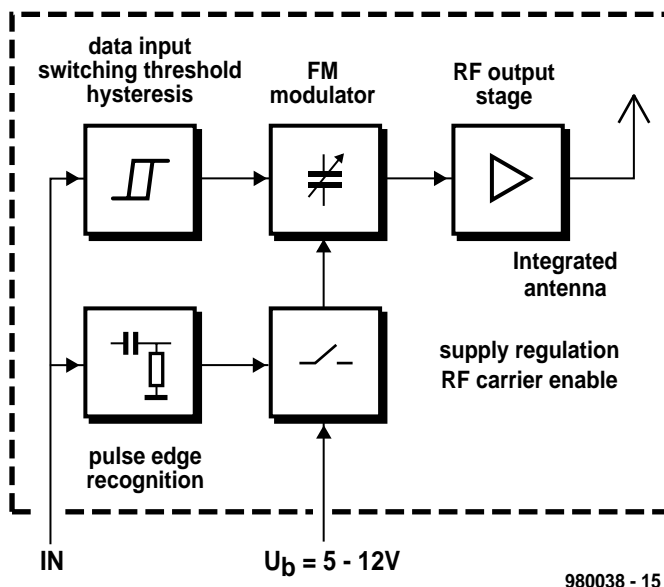

6

Figure 6. FM receiver modules may be superheterodynes or even double-conversion designs.

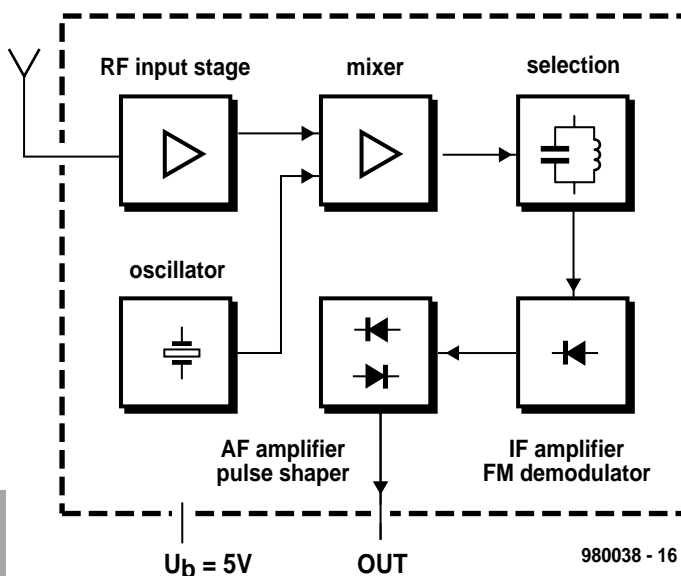

modules with even higher specifications are not necessarily larger, but dearer and more complex.

Higher-spec transmitters achieve better frequency stability thanks to the use of a crystal-controlled synthesiser, while the harmonics suppression is also better as a result of extensive filtering at the output.

Likewise, high-end SRD receiver modules are usually double-conversion types using synthesiser tuning and narrow-band IF filters. The technology

used to manufacture these modules is the same as found in handhelds for the 70-cm amateur radio band.

DATA TRANSMISSION

For simple data transmission applications, such as a remote control link, you need a suitable encoder at the transmitter side, and a matching decoder at the receiver side. Specially designed integrated circuits are available like the MM57410N from National Semiconductor, the MC145026/MC145028 from Motorola,

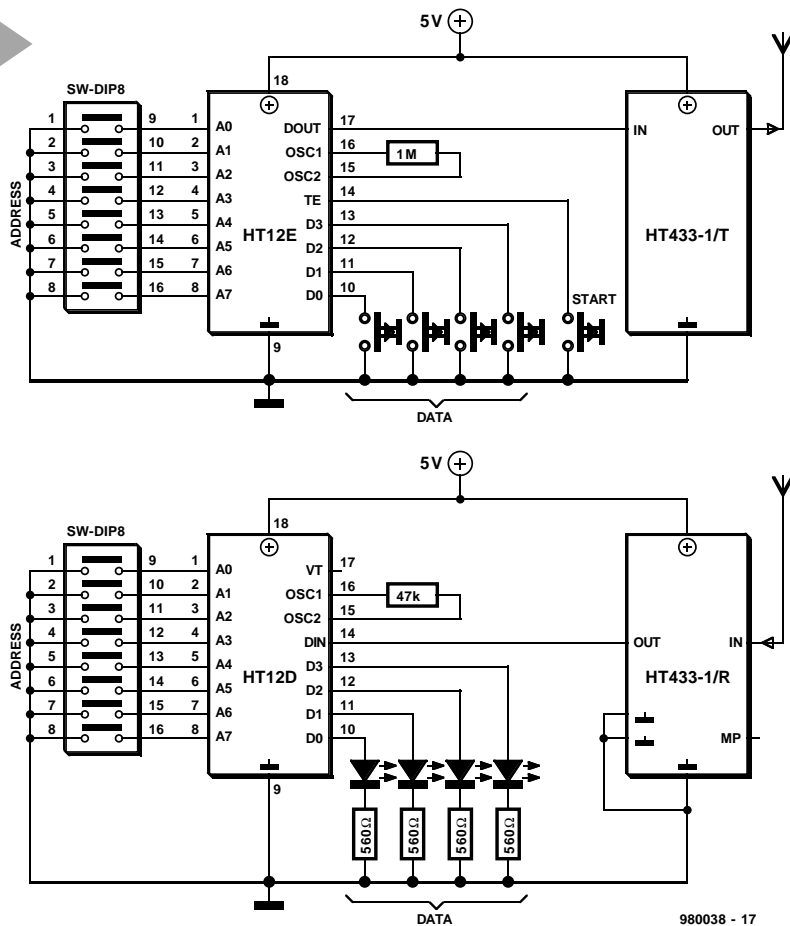

Figure 7. Application circuit for an addressable digital link using an SRD and frequency modulation (FM).

or the HE8 and HT12 from Heiland Electronic (D-48351 Everwinkel, Germany. Tel. +49 2582-7550,

fax +49 2582-7887).

An example of an addressable signal transmission link for the 433 MHz SRD band is shown in **Figure 7** (note: this application may not be allowed in the UK). The encoder IC type HT12E supplies its data directly to the modulation input of the transmitter. Simi-

larly, the HT12D decoder IC is found directly at the output of the receiver. On the DIP switches in the encoder you set the same address as in the receiver to be addressed (multiple receivers may be addressed by a single transmitter).

In addition to the receiver address, four data bits may be applied to the input. Here, these four bits come from push-button switches. By applying the transmit-enable signal (/TE), the encoder is prompted to supply a 12-bit serial word (consisting of 8 address

bits, and 4 data bits) to the transmitter. The decoder receives the 12-bit word and extracts the first 8 bits as an address, and the remaining 4 bits as data. The four data bits only appear at the output if the received address matches the DIP switch setting in the decoder. The 4-bit dataword is first latched and then used to control external devices (here, LEDs are used).

To make sure the transmission arrives securely at the decoder, the encoder transmits the 12-bit serial word four times each time the /TE input is activated. The decoder withholds the data until three identical, successive, copies have been received. The VT output then flags the availability of valid data.

This process is very well suited to slow data transmission. For higher data rates, a microcontroller is an obvious alternative to special encoder/decoder ICs. Note, however, that opting for a microcontroller (like a PIC) almost always means that you have to write your own software aimed at achieving secure and reliable transmissions.

If data is to be exchanged between equipment having a serial interface, the first solution that comes to mind is often one as adopted in the project 'Long-distance IrDA link' published in *Elektor Electronics* May 1997.

For more demanding telemetry applications, special data modems are employed in combination with high-end 418-MHz SRD modules. A transmission protocol is then used to improve the data security. Often, the AX.25 protocol is employed, a spin-off of the X.25 protocol which has been in use for several years for amateur packet radio.

MODULATION TECHNIQUE — A BOTTLENECK

While most data transmission modules approved for SRD use are usually said to use 'FM', in practice the actual modulation method is FSK (frequency shift keying). Though simple from a design and technology point of view, FSK is burdened by a large bandwidth requirement which is the chief cause of the relatively short distances that can be covered. Assuming a receiver bandwidth of 25 kHz (at -36 dBm) is being used for data transmission, then the highest achievable data rate using FSK would be a measly 500 bits per second! Consequently, professional applications of SRD modules call for special modulation techniques like GMSK (Gaussian Minimum Shift Keying) which reduce the bandwidth requirement by a factor of 15 and more, while considerably improving the transmission security.

(980038-1)

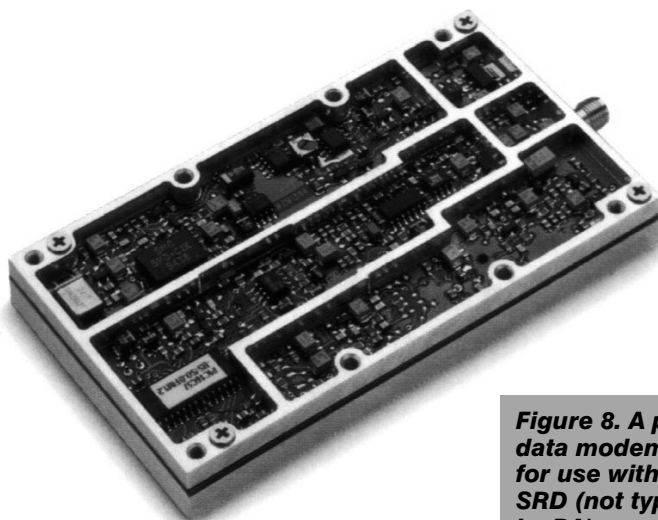

Figure 8. A professional data modem designed for use with a 70-cm SRD (not type-approved by RA).